



Nordic



ART. NO. 120059

EN

INSTALLATION INSTRUCTIONS

Cooling coil ø200

Contents

1. Cooling coil for ventilation air4
2. System diagram5
3. Plumbing work6
4. Dimensioned drawings8
5. Configuration9
6. Circuit diagram 12
7. Electrical connections 14
8. Maintenance 16
9. Accessories 17



All electrical connections must be made by a professional electrician.

*Our products are subject to continuous development and we therefore reserve the right to make changes.
We accept no liability for printing errors.*

1. Cooling coil for ventilation air

Included in cooling coil

- Coil unit
- Cables
- Supply air sensor (B1) WAGO clamps and bundle ties

Implementation

The housing is made from aluzinc-coated sheet steel, AZ 185. Coil with pipes and pipe connections in copper and fins in aluminium.

Opening hatch for ease of inspection and cleaning. Stainless steel drip tray (EN 1.4301) for condensate, with drain outlet (G½"). Duct connections have rubber seals.

Duct cooler fulfils leakage class C in EN 15727, ensuring that the cooled air reaches its destination without leaking from the ventilation system - thus saving energy and costs.

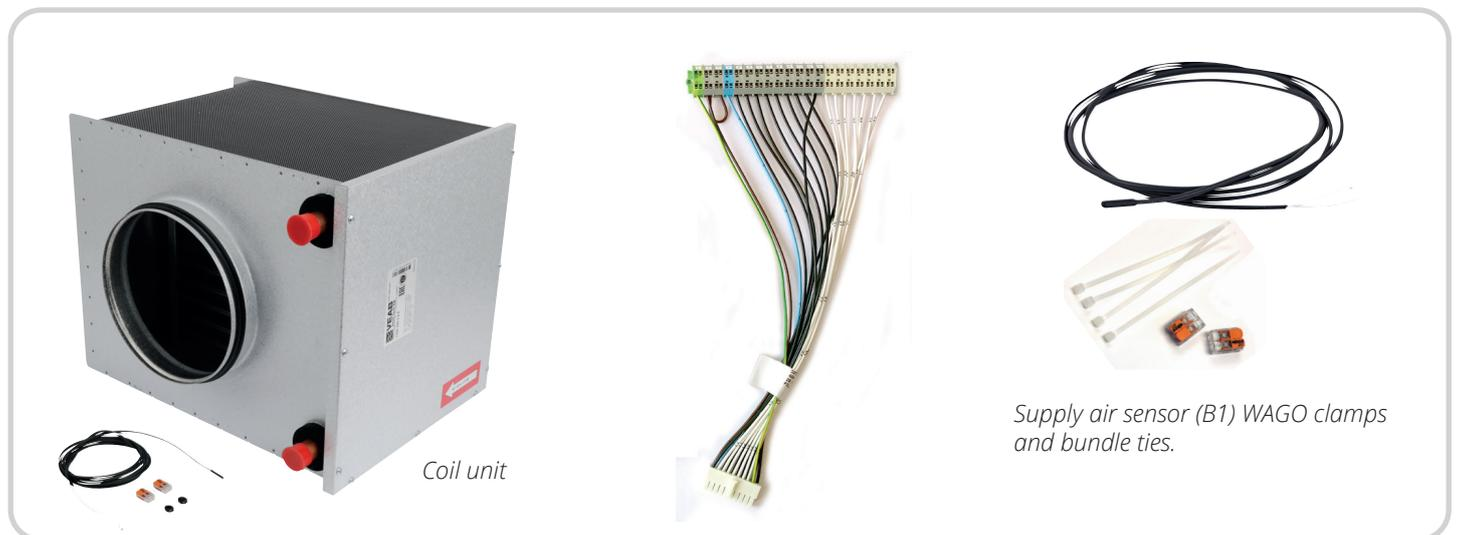

Coil unit

Supply air sensor (B1) WAGO clamps and bundle ties.

Accessories

- Shunt valve
- Shunt valve motor
- Damper
- Circulation pump (not part of Flexit range)

See complete list with article numbers in chap. 9. Accessories on page 17.

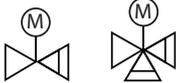
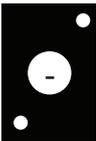
<p>Symbol</p>	 Pump	 Non-return valve
 Shunt valve with motor	 Cooling coil	 Grille
 Damper with motor and return spring	 Temperature sensor	
 Adjustment valve, manual		

2. System diagram

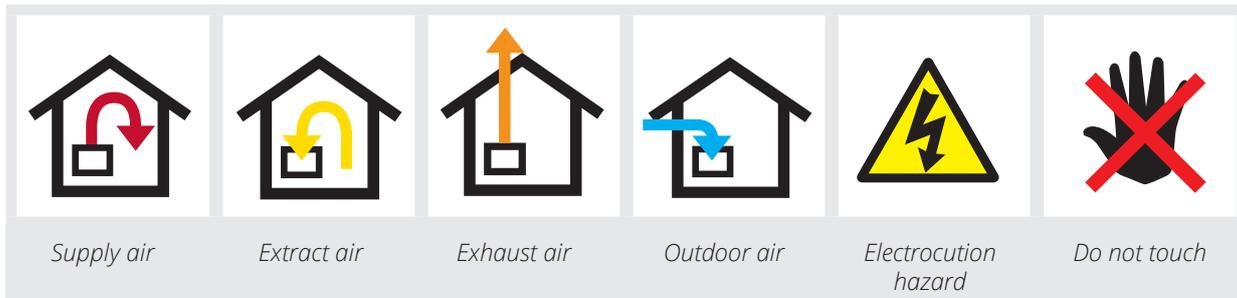
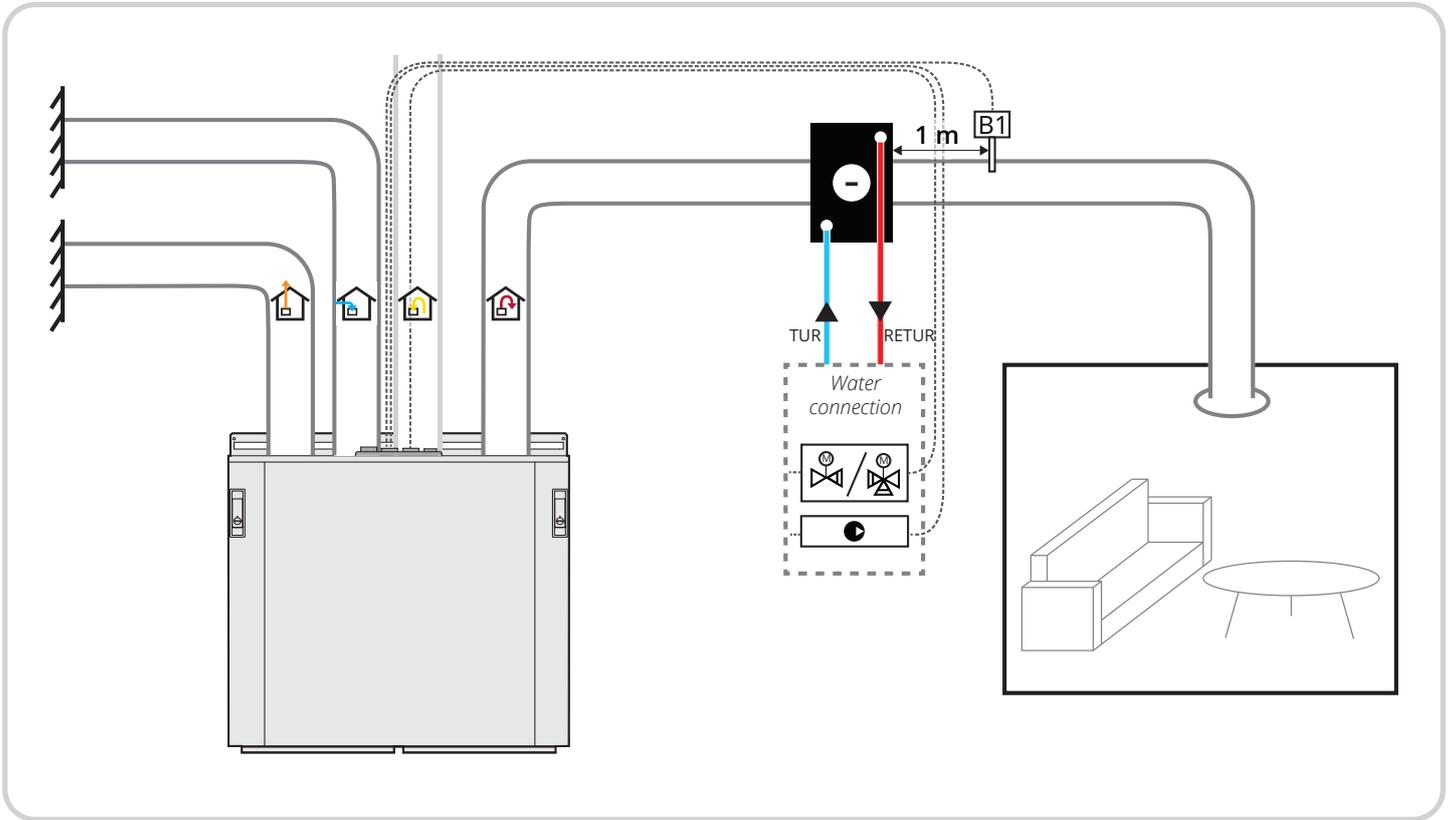

Draining

During lengthy stoppages or periods where the temperature is below the freezing point of the cooling water, the water in the coil must be drained off.

3. Plumbing work

Connection of cooling water

When connecting the cooler to the pipe system, please observe the following:

1. The cooler connection must be executed according to the provisions in force.
2. Under no circumstances may the connection pipes to the coil be subject to torsional or bending stress when mounting couplings etc. Use tools to hold the parts in place during assembly.
3. Make sure that the expansion forces in the system or the deadweight of the pipe system do not put a strain on the coil connections.
4. The water inlet must usually be the bottommost connection pipe, in order to facilitate venting of the coils. A vent point on the coil or at the highest point of the system will usually be necessary.
5. The duct cooler must be connected in such a way that it is easy to empty the system, e.g. in case of repairs, lengthy stoppages or where there is a risk of freezing.
6. Immediately after filling the system with cooling water, check the duct cooler and its connection for any leaks, as these could cause water damage.

Installation

The duct cooler is suitable for insertion in a standard spiral duct. Fixation is performed with screws. The cooler should not be mounted near a fan outlet or duct bend, as this risks uneven airflow over the coil, resulting in lower efficiency. An efficient filter is recommended in the system in order to reduce maintenance. See under Maintenance.

The duct cooler can only be mounted in a horizontal duct, with air direction as shown by the mounted arrow. The duct cooler must be insulated externally to avoid condensate forming on its exterior. Normally, the ducts transporting the cooled air must also be insulated to prevent condensation. The duct cooler requires a drain for removing any condensate. To avoid unnecessary condensate collecting in the duct cooler, the assembly must be inclined 10-15 degrees in the direction of the drain. - See sketch below. The drain connection is G 1/2. The duct cooler must be connected to the drain so as to avoid any tension, pressure or torsion on the drain connection. Otherwise there will be a risk of water leakage.



WARNING! Before beginning work: Disconnect the power supply and wait 2 minutes before opening the door.



The coil must be mounted to permit access for servicing and cleaning.

Operating data:

Max. operating temperature: 150°C

Max. operating pressure: 1.0 MPa (10 bar)

Dimensioning and calculation of cooling effect is performed in Flexit Select. (<https://flexitselect.flexit.no/>)

For more information, see www.flexit.se

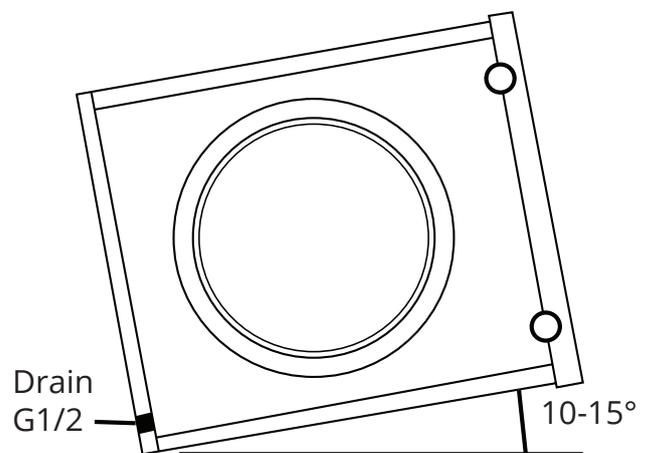

Venting

Remember to install the T-piece for venting at the top point of the circuit.



The cooling water mixture must be adjusted to secure frost prevention equivalent to the dimensioning outdoor winter external temperature (DVUT) in which the product is to be used. If the cooling water cannot be dimensioned down to the DVUT, the product must be emptied and drained prior to the winter season. If the cooling water freezes, the coil unit may burst apart, causing water to flow from the system, with the attendant water damage.



All functions must be tested prior to starting operation.



The cooling coil must be installed in a room with a drain.

Connections

Position the shunt valve as close to the cooling coil as possible (preferably no more than 2m). Note that many valve motors are bidirectional and the direction can be set on the motor. Set it so that the valve opens in response to a rising 0-10 V signal, where 0V = closed and 10V = fully open.

4. Dimensioned drawings

Cooling coil $\varnothing 200$, Art. no. 120059

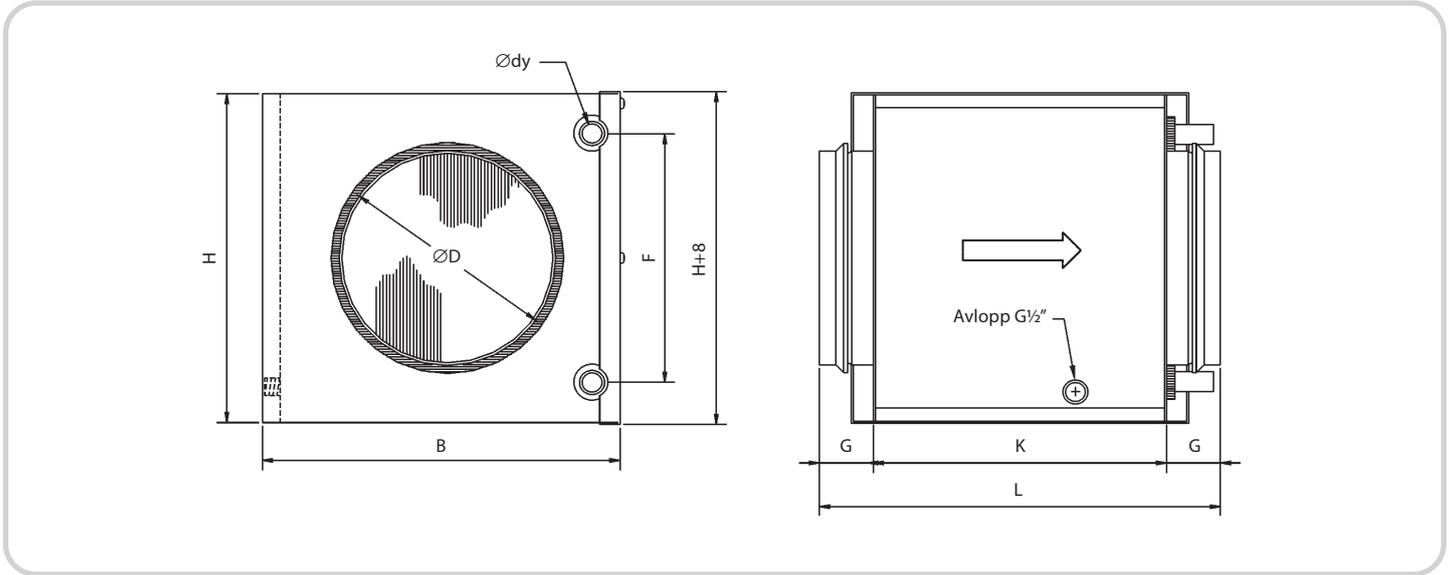

Type	Ø D mm	B mm	H mm	Ø dy mm	F mm	G mm	K mm	L mm	Internal pipe volume, litres	Weight in kg
Cooling coil 120059	200	411	330	22	250	40	280	360	0.7	9

5. Configuration

Necessary condition: Connect a mobile phone/tablet to the same network as the product before starting the Flexit GO app.

1 Welcome to Flexit GO. For controlling your product, please login or register your product. Options: Login, Register product, Find product.

2 Refresh list. Choose which product you want to connect to. Product list shown with 'Connect' button.

3 Refresh list. Product selected with a checkmark. 'Connect' button highlighted.

4 Enter 'basic' or enter code for installer or service user. Code input field with '1000' entered. 'Login' button highlighted.

5 Home screen showing temperature controls for 'Air' and 'Home'.

6 Home screen with 'More' button highlighted.

7 'More' menu with options: Installer, Additional functions, Alarm, System info, Operating hours, Service, About Flexit GO, Sign out. 'Installer' highlighted.

8 'Installer' menu with options: Configuration, Commissioning, Communication. 'Configuration' highlighted.

9 'Configuration' menu with options: Configure functionality, Configure hardware I/O. A 'Configuration mode!' dialog box is shown with 'OK' highlighted.

10 'Configuration' screen with a 'Stopping application...' progress indicator. 'Apply' button at the bottom.

11 'Configuration' menu with 'Configure functionality' highlighted. 'Apply' button at the bottom.

12 'Configure functionality' screen with options: Temperature control ventilation, Supply air control, Fan control, Dehumidify control, Heating coil, Electrical, Cooling coil, None, Fire damper, No. 'Temperature control ventilation' highlighted. A note at the bottom: 'For optimum cooling function, temperature regulation should be changed to "Extract Air/Cascade Regulation" in the summer season.' 'Done' button at the bottom.

13

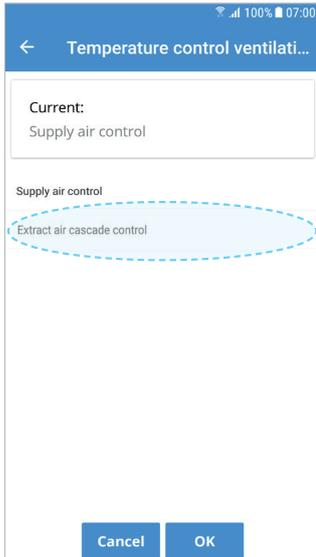

14

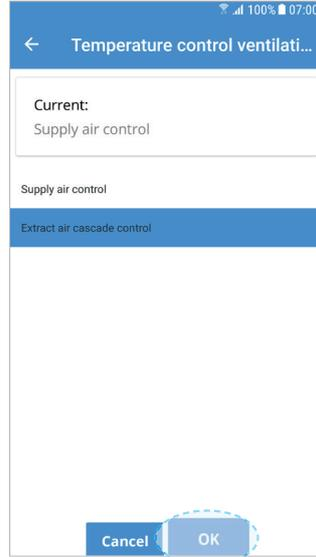

15

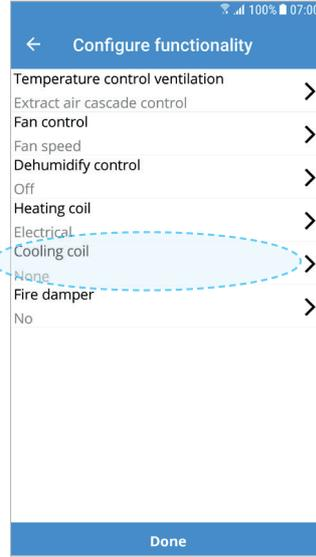

16

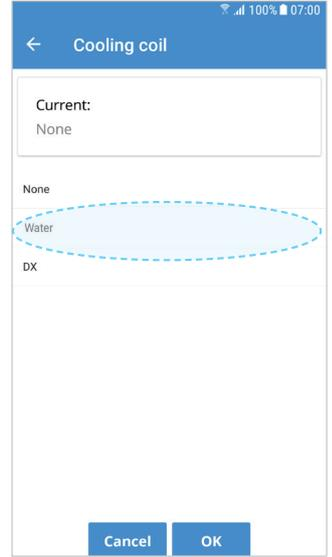

17

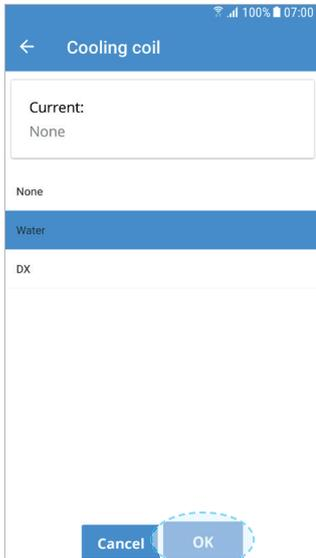

18

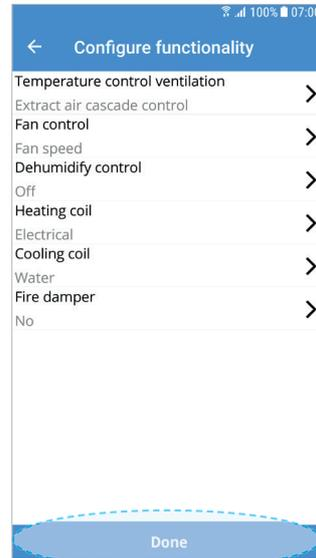

19

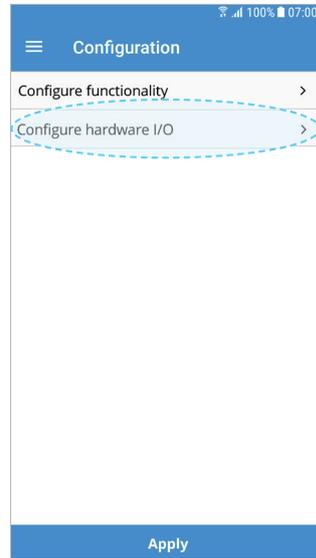

20

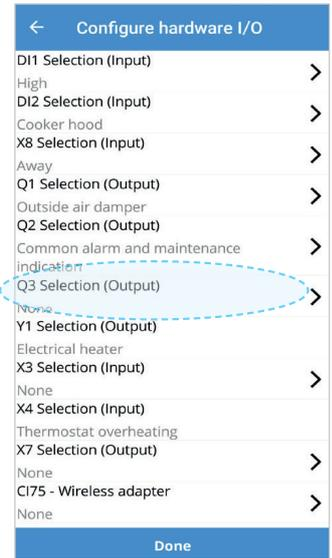

21

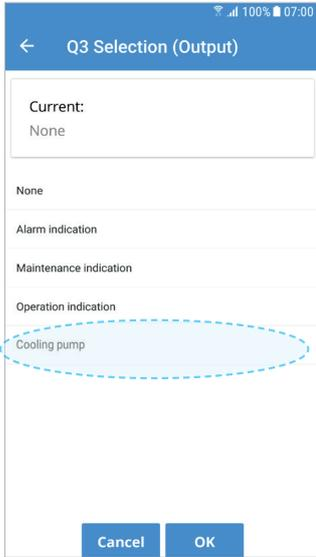

22

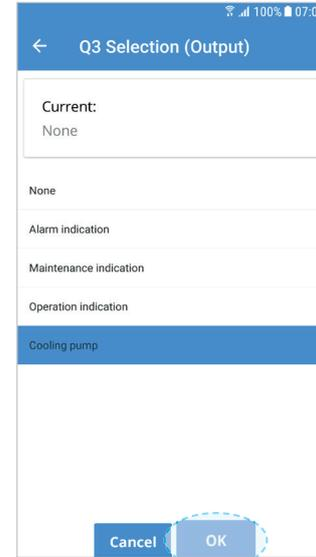

23

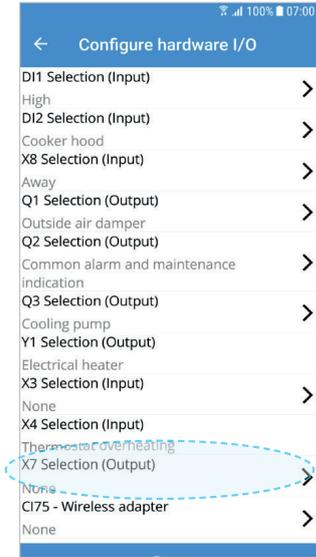

24

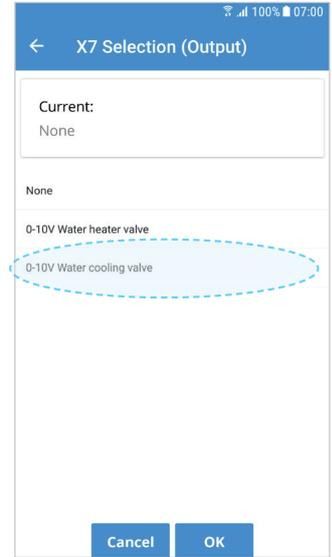

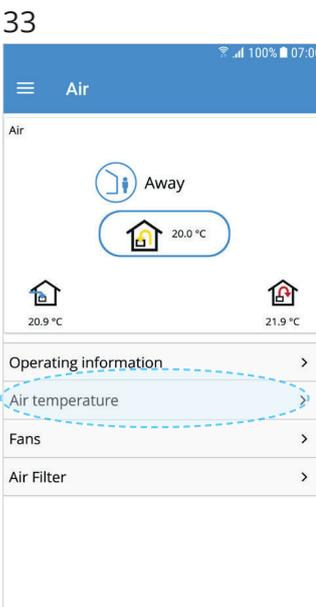
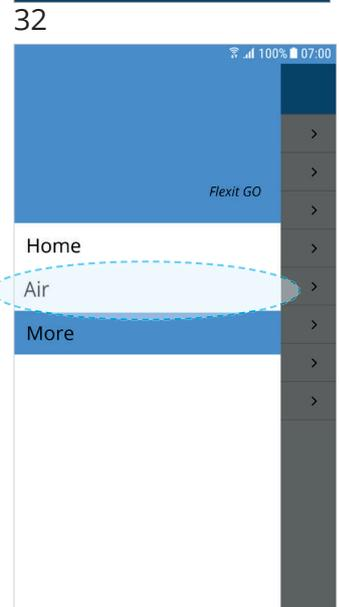
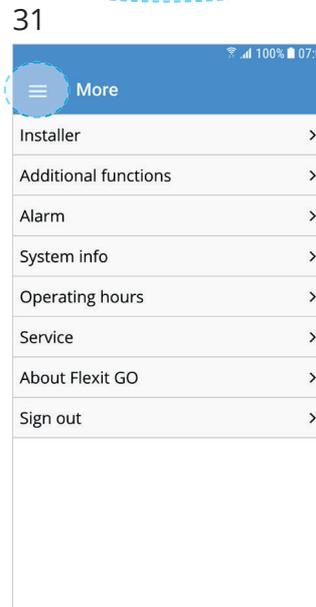
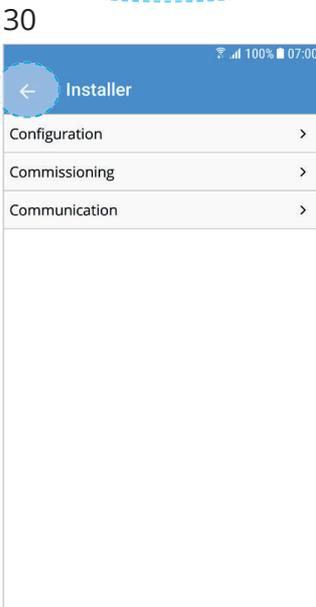
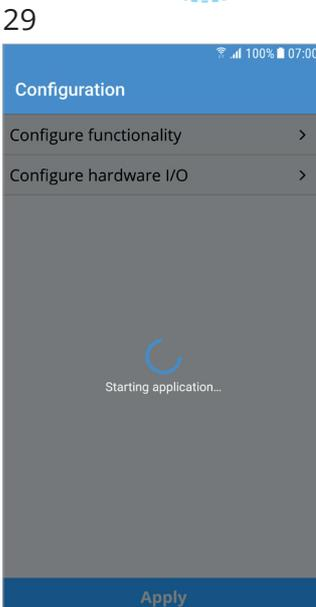
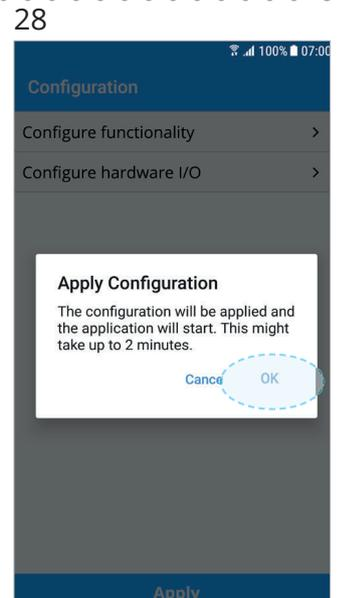
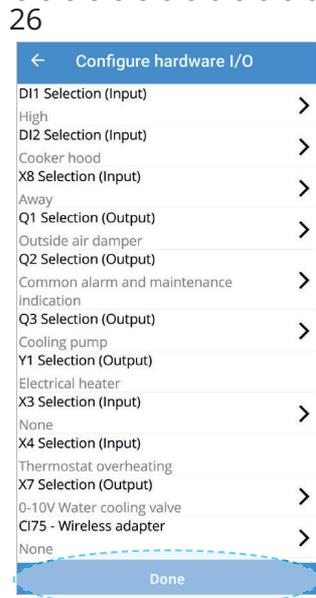
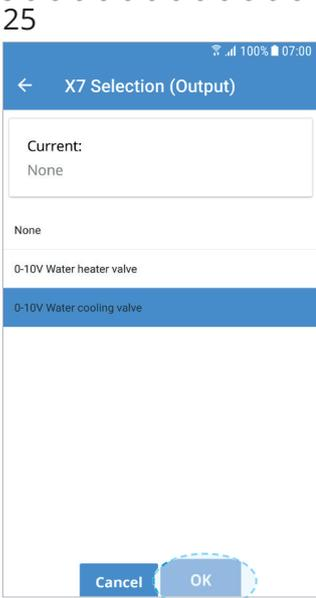

Adjust the outdoor air temperature limit for startup of cooling.

Adjust the target temperature for the desired indoor temperature.

Adjust the permitted temperature range for supply air. NB. Min temperature must not be set so low that there is a risk of condensation in the duct system.

6. Circuit diagram

NB. The terminal block numbers are not included in the number series in the examples.

Circulation pump motor 230V.
Diagram shows connections for configuration according to the manual (cooling pump on relay output Q3)

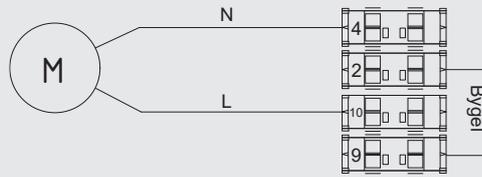

Relay output	N	L	Jumper
Q1	4	6	2-5
Q2	4	8	2-7
Q3	4	10	2-9

Shunt valve motor 230V
Cooling coil vent

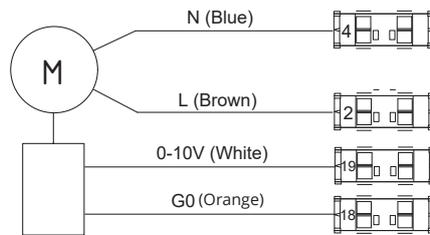

L (230V) is provided on both block no. 2 and 3.

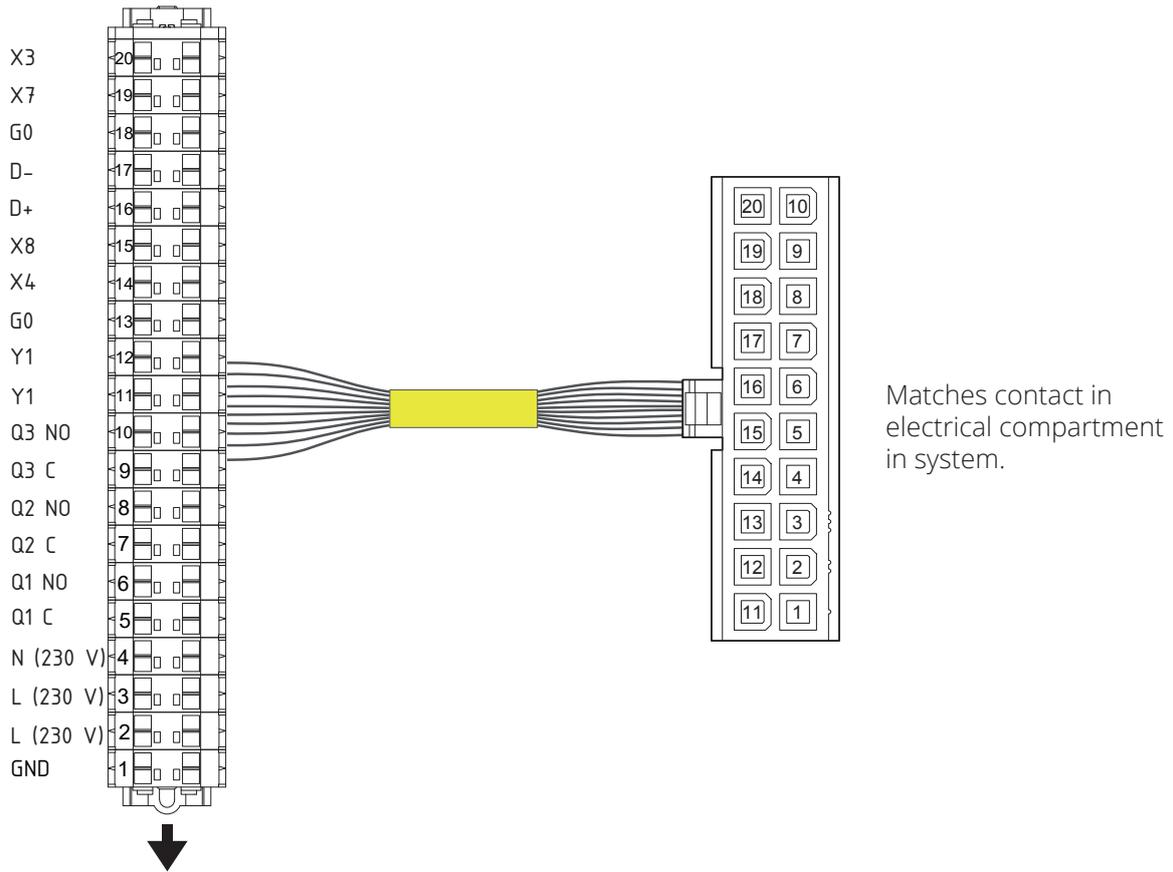

1	GND	Protective earth
2	L (230 V)	L 230 V
3	L (230 V)	L 230 V
4	N (230 V)	N - 230 V
5	Q1 C**	Supply digital output 1
6	Q1 NO*	Digital output 1 normally open The following options are available: None <u>Outdoor air damper</u> Fire damper Common alarm/maintenance Alarm indicator Maintenance indicator Operation indicator Bypass damper Cooling pump
7	Q2 C**	Supply digital output 2
8	Q2 NO*	Digital output 2 normally open The following options are available: None <u>Outdoor air damper</u> Fire damper <u>Common alarm/maintenance</u> Alarm indicator Maintenance indicator Operation indicator Bypass damper Cooling pump
9	Q3 C**	Supply digital output 3
10	Q3 NO*	Digital output 3 normally open The following options are available: None <u>Outdoor air damper</u> Fire damper Common alarm/maintenance Alarm indicator Maintenance indicator Operation indicator Bypass damper Cooling pump

11	Y1*	Digital output Y1 (230 V) The following options are available: None Battery <u>Pump water coil</u>
12	Y1*	Digital output Y1 (230 V) The following options are available: None Battery <u>Pump water coil</u>
13	G0	Signal earth
14	X4*	Digital or analogue output The following options are available: None Overheating thermostat Return water sensor
15	X8*	Digital input X8 The following options are available: None Home <u>Away</u> Emergency stop CO detector Smoke detector - extract air Smoke detector - supply air Smoke detector - off Smoke detector - max Fire damper feedback
16	D+	Modbus slave D+
17	D-	Modbus slave D-
18	G0	Signal earth
19	X7*	Analogue output 0-10 V The following options are available: None 0-10V valve water coils heating <u>0-10V valve water coils cooling</u>
20	X3*	Analogue output 0-10 V The following options are available: <u>None</u> 0-10V Air humidity sensor 0-10V CO ₂ sensor

* These inputs/outputs may have different functions depending on the configuration selected via Flexit GO. The underlined options are standard on units configured for water heating.

** Max voltage 230 V AC, max current 2A resistive load.

7. Electrical connections



All electrical connections must be made by a professional electrician.



WARNING! Before you begin work: Disconnect the power supply and wait 2 minutes before opening the door.

1

Remove the lid from the electrical cabinet

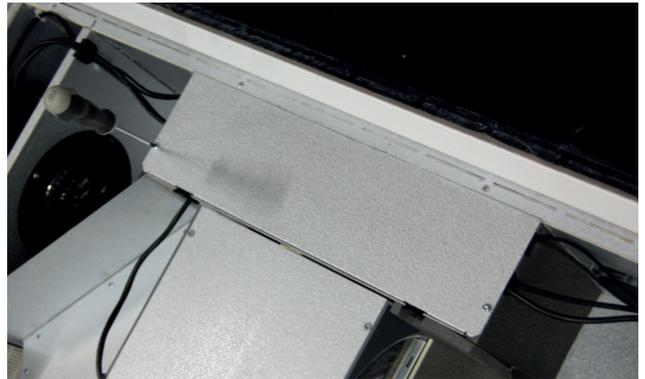

2

Localize the temperature sensor (B1) and cut it off.
TIP: Follow the sensor from the supply air fan into the electrical compartment.

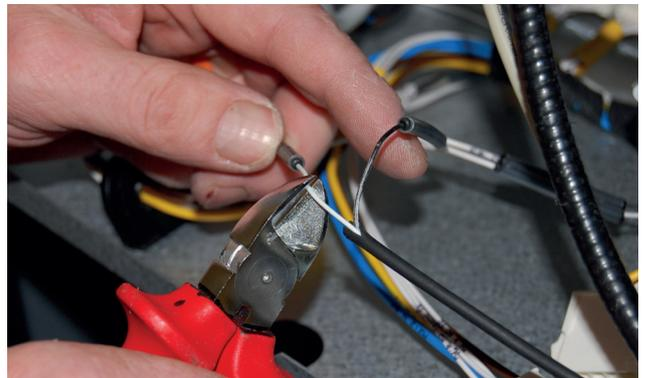

3

Splice the supplied NTC sensor with the ends of the freshly cut cables. NB Splice the cables which lead to the controller card.

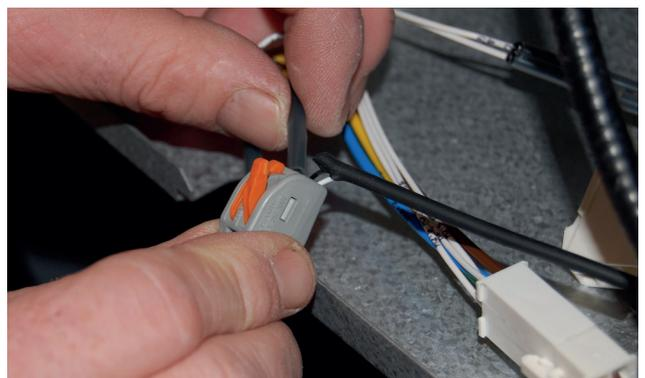

4

Connect all cables to the terminal block according to the circuit diagram, before pressing it into place on the electrical compartment wall.



5

Connect the contacts in the electrical compartment.

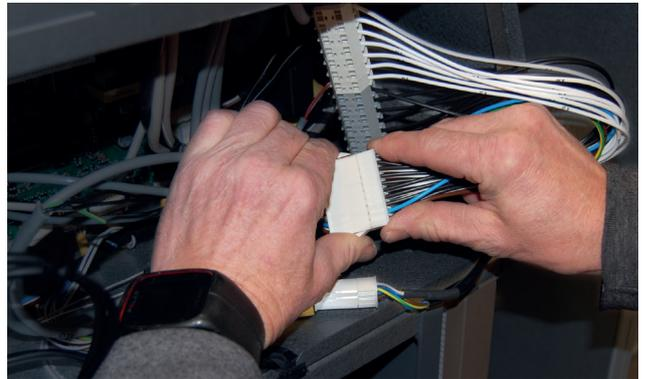

6



Temperature sensor (B1) must be positioned after the water coil.

The temperature sensor supplied with the cooling coil must be positioned in the supply air duct (cf. label on unit) approx. 1m after the cooling coil. Drill a 7 mm hole in the duct in which the sensor can be placed. Seal the hole with sealant and tape the wire in place on the outside of the duct.



7

Use the cable entries on the unit for connecting external components. Connect the shunt motor and circulation pump as shown on the wiring diagram, point 6.

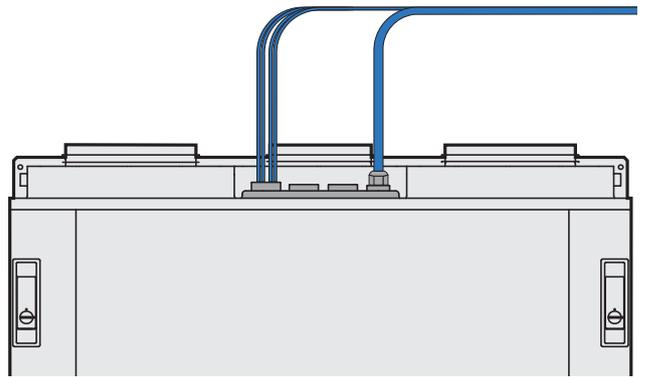

8. Maintenance

To achieve the full effect of the heater/cooler, the coil must be cleaned at regular intervals. The time between cleaning will depend entirely on the cleanness of the air and how well the filter and the rest of the unit are maintained.

The coil is easily accessible for cleaning once the heater/cooler lid is removed. Clean the inlet side of the coil first using a brush, after which the whole coil unit can be cleaned with compressed air, water or steam.

Blow or flush the dirt away from the outlet side towards the inlet side. Cleaning is easier if a mild solvent is used (having confirmed that the solvent does not attack copper or aluminium).

Be careful not to damage the thin edges of the fins.

9. Accessories



Shunt valve:

- For continuous regulation of hot or cold water in open or closed circuits
- Flow control of heater/cooler in air conditioning plant.
- Bubble tight closure in closed position
- Cold or hot water which may be mixed with anti-freeze liquid by up to 50% vol.

3-way

3-port regulating valve with linear (equal percentage) flow characteristic.

Internal threaded connection Rp 1/2", DN 15
 Housing nickel-coated hot-pressed brass
 Valve cone housing stainless steel
 Seal PTFE/EPDM O-ring
 ps 1600kPa

2-way

2-port regulating valve with linear (equal percentage) flow characteristic.

Internal threaded connection Rp 1/2", DN 15
 Housing nickel-coated hot-pressed brass
 Valve cone housing stainless steel
 Seal PTFE/EPDM O-ring
 ps 1600kPa



Shunt valve motor:

AC 100-240V 50/60Hz
 Operating power consumption 1.5W at nominal torque
 in standby 0.4W for dimensioning 4VA.
 Connection cable 1m 3x0.75mm²
 Torque min 5Nm at rated voltage
 Sound level max 5dB(A) without valve
 Position indicator
 Mechanical
 Protection class 2
 Enclosure class IP54

Overview	
56596	Motor for shunt valve
Shunt valves	
110939	2-way valve DN15 Kvs 0.25
110940	2-way valve DN15 Kvs 0.4
110941	3-way valve DN15 Kvs 0.25
110942	3-way valve DN15 Kvs 0.4

111812	2-way valve DN15 Kvs. 0.63
111813	3-way valve DN15 Kvs. 0.63
111814	2-way valve DN15 Kvs. 1.0
111815	3-way valve DN15 Kvs. 1.0
112817	2-Way valve DN15 Kvs 1.6
112818	3-Way valve DN15 Kvs 1.6
112815	2-Way valve DN15 Kvs 4.0
112816	3-Way valve DN15 Kvs 4.0



Flexit AS, Televeien 15, NO-1870 Ørje
www.flexit.se